

TEST CERTIFICATE - EARTH LEAKAGE RELAY

Serial No: DELR -

DATE:

- 1.Input Voltage : 230V AC , SINGLE PHASE
- 2.Leakage Current Settings : 1A(minimum)
: 8A (maximum)
- 3.Time Delay settings : 0.3 to 3 Secs
- 4.Repeat Accuracy : 10%
- 5.Relay Condition : Relay energizes on fault.
- 6.Indications : RED LED glows when fault occurs and relay energizes
GREEN LED glows to indicate Auxiliary supply
- 7.Output Contacts : NO + NC provided.
- 8.CBCT :

CONNECTIONS - Connect Input supply of 230V AC, single phase,50Hz to the backside of the ELR marked P&N. Connect the terminals C T1 and CT2 to the CBCT terminals marked CT1 and CT2.

Set off contacts : NO for terminals marked N/O and NC for the terminals marked C and N/C.
Setting : Set the current setting to the required range from 1A to 8A and set the time setting range to the required time delay ie. From 0.3 to 3 secs(it is preferable to keep the current setting to minimum ie.,1A and the time delay setting to minimum ie.,0.3sec's).

Test Results

(When passing required current)
(With the time delay setting at 0.3secs)

Current setting on Relay	Actual Current tripping when measured with Multimeter
1AMP	
8AMPS	

At the time of tripping the GREEN LED remains and the RED LED glows, N/O of the relay close and the N/C of the Relay opens.

- Time delay at minimum (0.3 sec) : Relay energies immediately.
- Indication** : RED LED glows when relay energies
- Insulation** : 20 Meg Ohms and above with 500V megger between body and terminals.
- Setting** : Current set at 1A. Time set at 0.3 sec.
- Tested By _____ Passed By _____ Checked By _____



MANUFACTURERS OF ELECTRICAL RELAY

EARTH LEAKAGE RELAY

1Amp - 8Amps

USER MANUAL

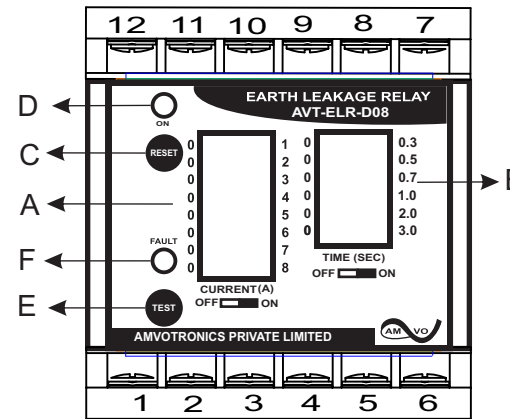

- A - DIP Switches for Current setting
- B - DIP Switches for Delay setting
- C - Reset button
- D - Power ON Indication
- E - Test button for testing the healthy of relay
- F - Fault indication LED

Casing Dimensions

Connection Diagram

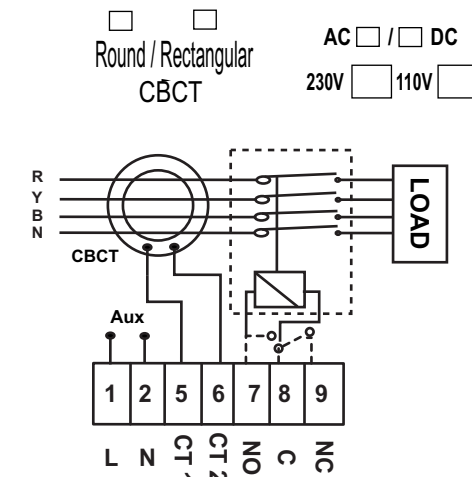
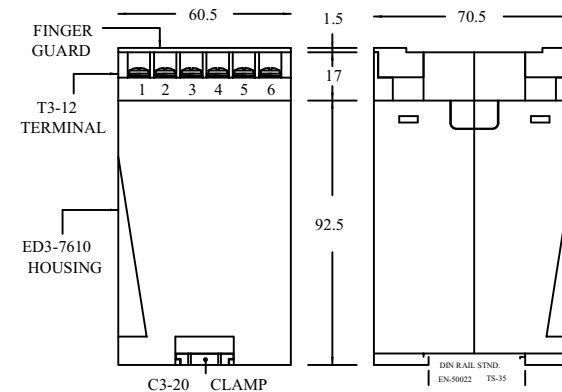

MODEL : AVT-ELR-D08

1. Settings

1a. Current Setting

Amps	DIP Switch Selection
1	1
2	2
⋮	⋮
7	7
8	8

This is for setting the minimum Earth Leakage current. This can be varied from 1Amp to 8Amps. Select any one required value for current, keep the other switch in OFF position.

1b. Delay Setting

Secs	DIP Switch Selection
0.3	1
0.5	2
⋮	⋮
2.0	5
3.0	6

This time delay setting is for setting the delay time from the start of fault to actual tripping of the relay contact. This can be varied from 0.3 to 3 Secs. Select any one required value for Delay, keep the other switch in OFF position.

2. Light Indicators

The light indicators display the status of the system.

Indicator		Status
AUX	TRIP	
Off	Off	No auxiliary power supply
On	Off	System Healthy
On	On	Trip due to Earth Leakage

3. Push Buttons

3a. Reset Button

The reset button is for resetting the relay and light indicators after an earth-leakage tripping has occurred. To reset, press the reset button once.

3b. Test Button

Test button is for checking the relay operation. Push on the test button to simulate an earth-leakage trip condition.

4. Electrical Specifications

Auxiliary Supply

AVT-ELR-D08	-	185-250 VAC
Supply frequency	-	50Hz
VA Rating	-	3 VA typical

Trip Contact

Rated Voltage	-	250 VAC
Continuous carry	-	5A(cos ϕ = 1.0)
Expected electrical life	-	100,000 operations
Expected mechanical life	-	5 million operations

Indicators

Auxiliary supply	-	Green LED indicator
Trip	-	Red LED indicator

Setting Ranges

Current (I _{>})	-	1Amp to 8Amps
delay time (DELAY)	-	0.3 sec to 3.0 sec

Mechanical

Mounting	-	Din-rail mounting
Approximate weight	-	160 Grams.

For further Sales and technical queries please contact:

AMVOTRONICS PRIVATE LIMITED, CHENNAI

CERTIFIED BY : CSIR



MADE IN INDIA